



EPLAN P8

Elektrodokumentation Electrical documentation

Hersteller:
Manufacturer: Boll & Kirch Filterbau GmbH
Siemensstraße 10-14
50170 Kerpen

Algemeine Daten:
General informations:

BK-Artikel-Nr.: 4302300
BK-Article-No.:

Projektdatei:
Project data:

Zeichnungs-Nr.: Z46604
Drawing-No.:

Typ: Filtertyp 6.61/6.61 Alarm DP
Type: Filter type 6.61/6.61 Alarm DP

Bezeichnung: Vollautomatischer Rückspülfilter
Designation: Fully automatic back flushing filter

Anzahl Seiten: 15
Number of pages:

Bearbeiter: ogoericke
Edited by:

Datum: 16.05.2019
Date:

Normen:
Specifications: Ausführung der Schaltanlage nach DIN EN 61439-5:2015-10. Bestimmungen für fabrikfertige Schaltgerätekombinationen mit Nennspannung bis 750V. Nennisolationsspannung 450/750V und Nennspannung 450/750V.
Execution of the switchgear according to DIN EN 61439-5:2015-10. Regulations for factory-fabricated switchgear combinations with rated voltage up to 750V. Rated insulation voltage 450/750V and rated voltage 450/750V.

Technische Kenngrößen
Technical characteristics

Gehäuse:
Housings:

Bezeichnung: KX 1575 Y231292
Designation:

Materialtyp: Stahlblech
Material: Carbon steel

Abmessungen: 300 x 300 x 155mm
Dimensionings:

Schutzart: IP65
Degree of protection:

Farbe: RAL7035
Color:

Türanschlag: Rechts
Door stop: Right

Montage: Wandabstandshalter
Mounting: Wall spacer

Gewicht: 15kg
Weight:

Leitungsfarben:
Wire colors:

Arbeitsstromkreis: Schwarz
Load circuit: Black

Schutzleiter: Grün/Gelb
PE conductor: Green/Yellow

Steuerstromkreis: Rot
Control circuit: Red

Fremdspannung: Orange
External voltage: Orange

Verdrahtung
Wiring

Hauptstromkreis wird mit 1,5mm² und Steuerstromkreis mit 1mm² verlegt.
Die Verdrahtung erfolgt von oben nach unten bzw. von links nach rechts gemäß den Stromlaufplänen.
The main circuit is laid with 1.5mm² and the control circuit with 1mm².
The wiring is carried out from top to bottom or from left to right according to the circuit diagrams.

Spannungen:
Voltages:

Betriebsspannung: 3~/PE
Operating voltage: 230-575V +/- 5%

Frequenz: 50/60Hz
Frequency:

Steuerspannung: 230V AC
Control voltage: 115V AC
24V DC

Sonstiges:
Miscellaneous:

Aderbeschriftung: -
Wire labeling:

Kabeltyp: H07V-K
Cable type:

Netzform: TN
Network types:

Umgebungstemperatur: 55°C
Environment temperature:

Kurzschlussfestigkeit (SCCR): 50kA
Short-circuit strength (SCCR):

Steuergerät: BK2300
Control device:

Getriebemotorleistung: 0,09 - 0,18kW
Gear motor power:

weitere Hinweise:
other notes:

Kabeleinführung: Cable entry:
 oben top unten bottom

Hauptschalter: Main switch:

vorne Front

links left

rechts right

Kundenvorschriften: Customer specifications:

Ja Yes Nein No

			Datum Date	16.05.2019		Hersteller Manufacturer Boll & Kirch Filterbau GmbH	Deckblatt Cover sheet Filtertyp 6.61/6.61 Alarm DP Filter type 6.61/6.61 Alarm DP	BK-Artikel-Nr.: 4302300	=
			Bearbeiter Edited by	ogoricke				BK-Article-No.:	+
REV01	Göricke	13.10.2021	Auftrag Order					Zeichnungs-Nr.: Z46604	Blatt Page
Revision Revision	Bearbeiter Edited by	Datum Date	Vorgang Process			Drawing-No.:	von of	15	

Inhaltsverzeichnis Table of contents

Anlage Plant	Einbauort Mounting location	Dokumentenart Document type	Seite Page	Seitenbezeichnung Page designation	Datum Date	Bearbeiter Edited by
		Schaltplan Wiring diagram	1	Deckblatt Cover sheet	08.09.2021	ogoricke
		Schaltplan Wiring diagram	2	Inhaltsverzeichnis Table of contents	13.10.2021	ogoricke
		Schaltplan Wiring diagram	3	Einspeisung und Stromversorgung Feed-in and power supply	08.09.2021	ogoricke
		Schaltplan Wiring diagram	4	Platine Circuit board	08.09.2021	ogoricke
		Schaltplan Wiring diagram	5	Getriebemotor Gear motor	08.09.2021	ogoricke
		Schaltplan Wiring diagram	6	Bedienfeld Control panel	08.09.2021	ogoricke
		Schaltplan Wiring diagram	7	Aufbauplan Assembling diagram	08.09.2021	ogoricke
		Materialliste Part list	8	Materialliste Part list	13.10.2021	ogoricke
		Materialliste Part list	9	Materialliste Part list	08.09.2021	ogoricke
		Klemmenplan Terminal diagram	10	Klemmenplan Terminal diagram	08.09.2021	ogoricke
		Klemmenplan Terminal diagram	11	Klemmenplan Terminal diagram	08.09.2021	ogoricke
		Klemmenplan Terminal diagram	12	Klemmenplan Terminal diagram	08.09.2021	ogoricke
		Klemmenplan Terminal diagram	13	Klemmenplan Terminal diagram	08.09.2021	ogoricke
		Klemmenplan Terminal diagram	14	Klemmenplan Terminal diagram	08.09.2021	ogoricke
		Klemmenplan Terminal diagram	15	Klemmenplan Terminal diagram	08.09.2021	ogoricke

			Datum Date	16.05.2019		Hersteller Manufacturer Boll & Kirch Filterbau GmbH	Inhaltsverzeichnis Table of contents Filtertyp 6.61/6.61 Alarm DP Filter type 6.61/6.61 Alarm DP	BK-Artikel-Nr.: BK-Article-No.:	4302300	=
			Bearbeiter Edited by	ogoricke				+		
REV01	Göricke	13.10.2021	Auftrag Order					Blatt Page	2	
Revision Revision	Bearbeiter Edited by	Datum Date	Vorgang Process			von of	15			
							Zeichnungs-Nr.: Drawing-No.:	Z46604		

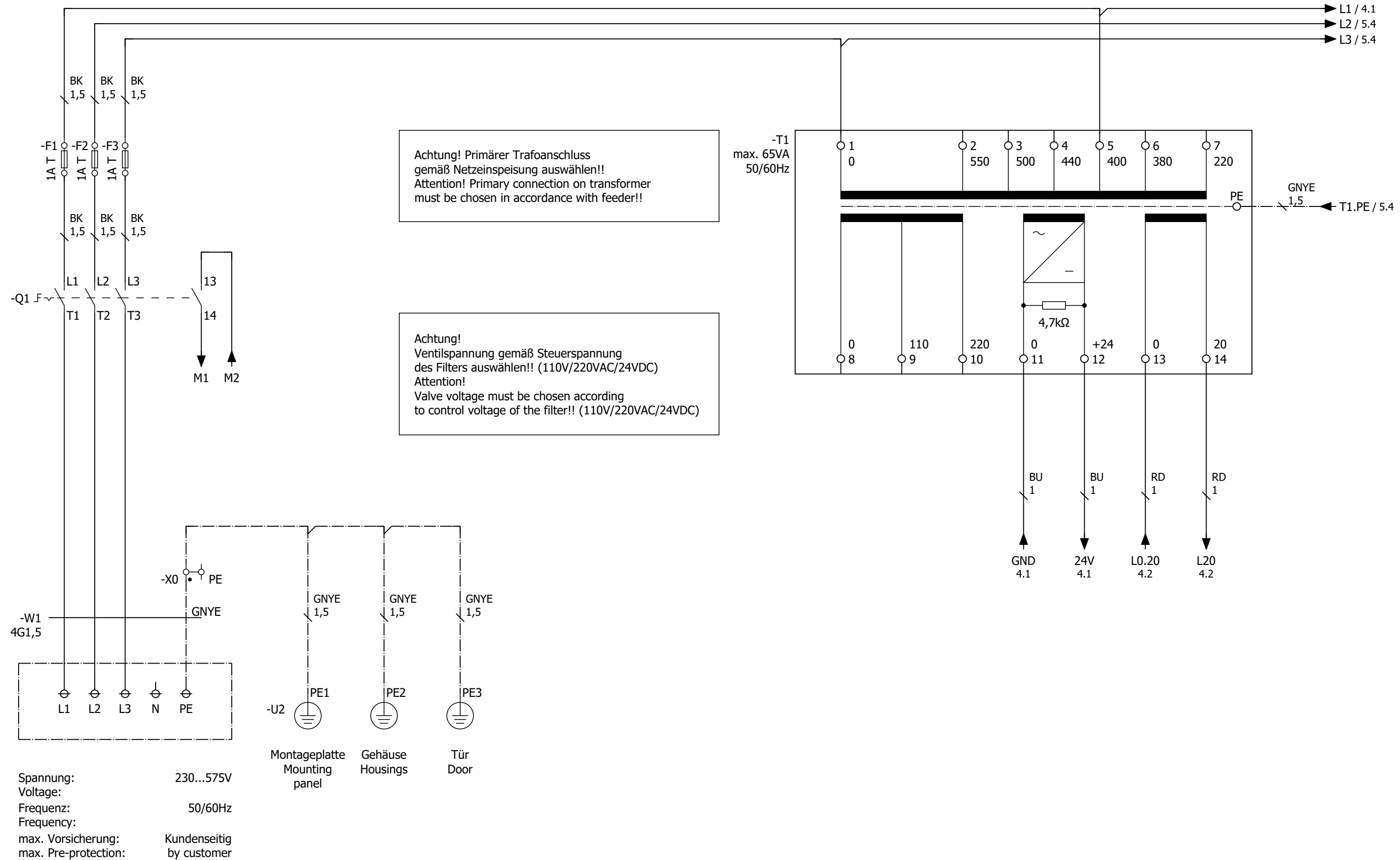

Alle nicht bezeichneten Leitungen = 1mm²
 All unnamed leads = 1mm²

			Datum Date	16.05.2019		Hersteller Manufacturer Boll & Kirch Filterbau GmbH	Einspeisung und Stromversorgung Feed-in and power supply Filtertyp 6.61/6.61 Alarm DP Filter type 6.61/6.61 Alarm DP	BK-Artikel-Nr.: 4302300	=
			Bearbeiter Edited by	ogoeरिकe				BK-Article-No.:	+
REV01	Göricke	13.10.2021	Auftrag Order					Zeichnungs-Nr.: Z46604	Blatt Page
Revision Revision	Bearbeiter Edited by	Datum Date	Vorgang Process			von of	15		

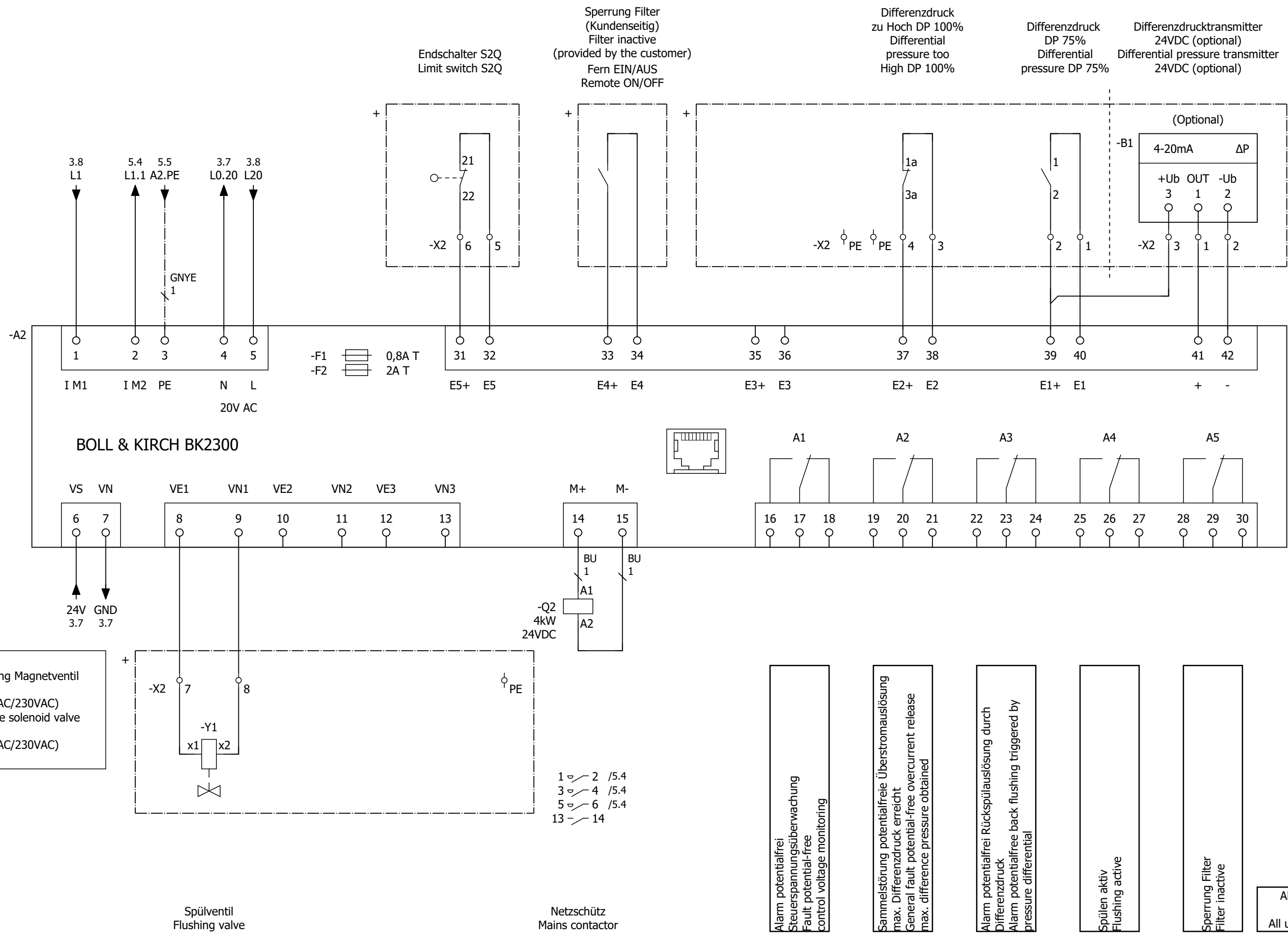

Steuerspannung Magnetventil
-Y1
(24VDC/115VAC/230VAC)
Control voltage solenoid valve
-Y1
(24VDC/115VAC/230VAC)

			Datum Date	16.05.2019
			Bearbeiter Edited by	ogoeरिकe
REV01	Göricke	13.10.2021	Auftrag Order	
Revision Revision	Bearbeiter Edited by	Datum Date	Vorgang Process	



Hersteller
Manufacturer
Boll & Kirch Filterbau GmbH

Platine
Circuit board
Filtertyp 6.61/6.61 Alarm DP
Filter type 6.61/6.61 Alarm DP

BK-Artikel-Nr.: 4302300
BK-Article-No.:
Zeichnungs-Nr.: Z46604
Drawing-No.:

=	
+	
Blatt Page	4
von of	15

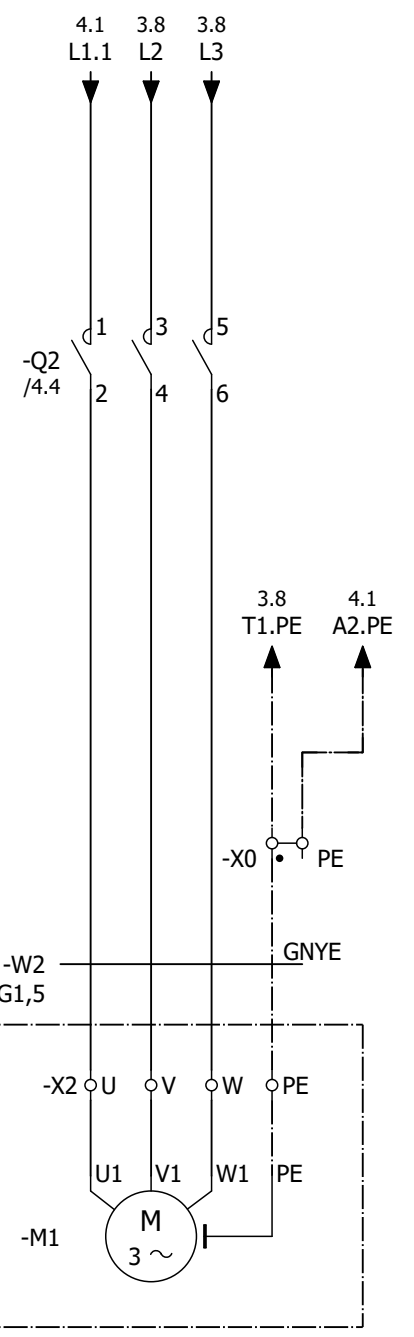

Getriebemotor
Gear motor

			Datum Date	16.05.2019		Hersteller Manufacturer	Getriebemotor Gear motor	BK-Artikel-Nr.: BK-Article-No.: 4302300	=
			Bearbeiter Edited by	ogoricke		Boll & Kirch Filterbau GmbH	Filtertyp 6.61/6.61 Alarm DP Filter type 6.61/6.61 Alarm DP	Zeichnungs-Nr.: Drawing-No.: Z46604	+
REV01	Göricke	13.10.2021	Auftrag Order						Blatt Page
Revision Revision	Bearbeiter Edited by	Datum Date	Vorgang Process					von of	15

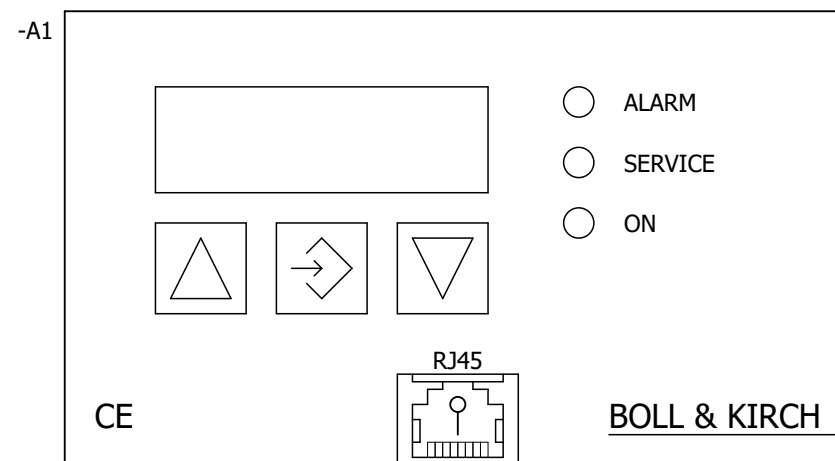

			Datum Date	16.05.2019		Hersteller Manufacturer	Bedienfeld Control panel	BK-Artikel-Nr.: BK-Article-No.:	4302300	=
			Bearbeiter Edited by	ogoeरिके		Boll & Kirch Filterbau GmbH	Filtertyp 6.61/6.61 Alarm DP Filter type 6.61/6.61 Alarm DP	Zeichnungs-Nr.: Drawing-No.:	Z46604	+
REV01	Göricke	13.10.2021	Auftrag Order							Blatt Page
Revision Revision	Bearbeiter Edited by	Datum Date	Vorgang Process						von of	15

-Z1

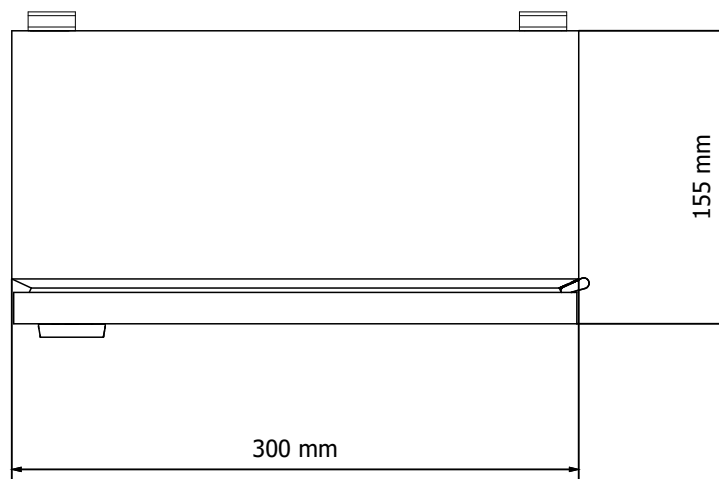
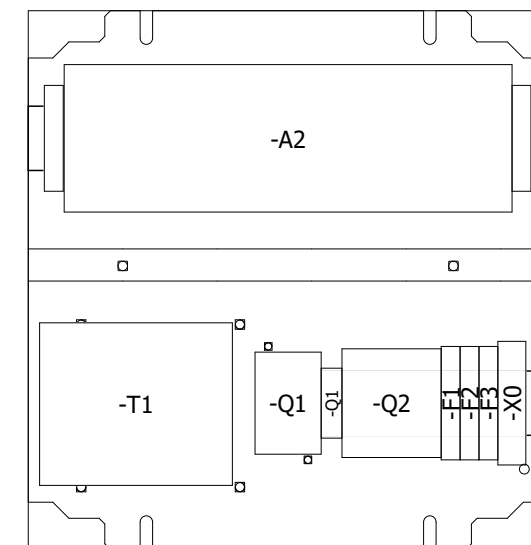
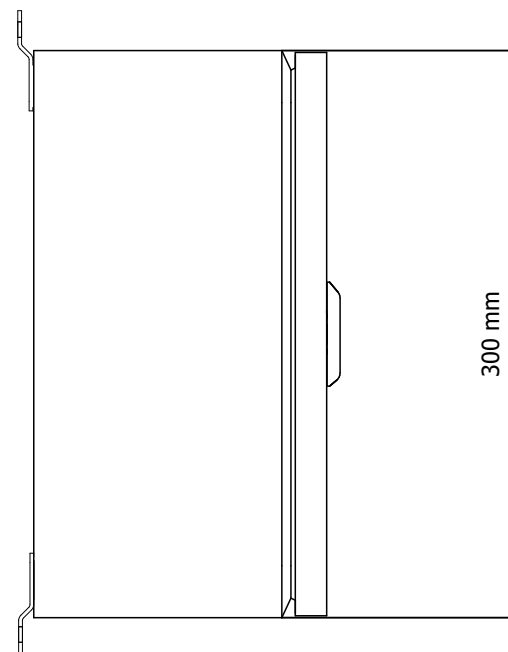
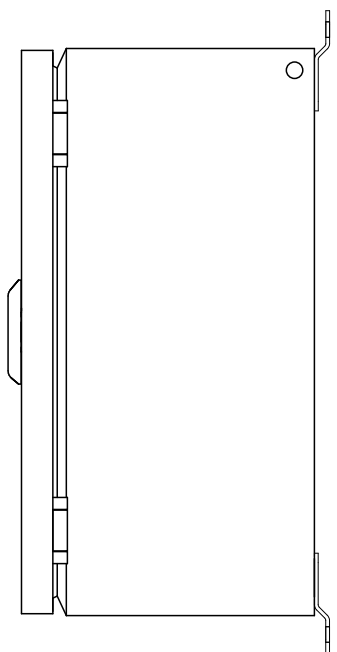
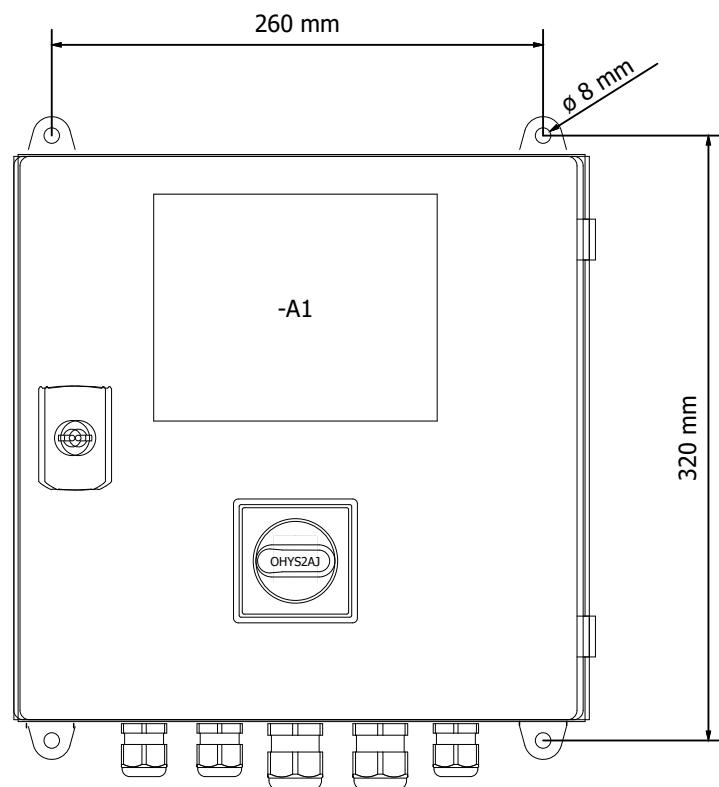
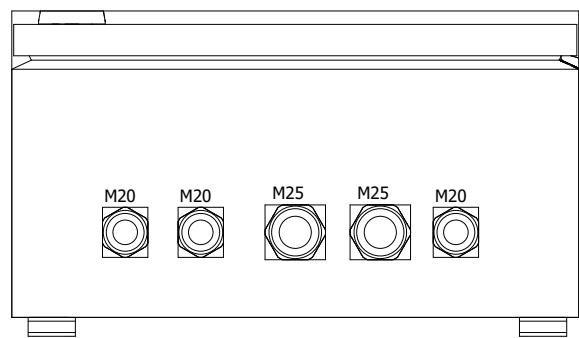

			Datum Date	16.05.2019		Hersteller Manufacturer	Aufbauplan Assembling diagram	BK-Artikel-Nr.: BK-Article-No.: 4302300	=
			Bearbeiter Edited by	ogoricke		Boll & Kirch Filterbau GmbH	Filtertyp 6.61/6.61 Alarm DP Filter type 6.61/6.61 Alarm DP	Zeichnungs-Nr.: Drawing-No.: Z46604	+
REV01	Göricke	13.10.2021	Auftrag Order						
Revision Revision	Bearbeiter Edited by	Datum Date	Vorgang Process					von of	15

Materialliste

Part list

Nr. No.	BMK DT	Anzahl Quant.	Bezeichnung Designation	Hersteller Manufacturer	Typ Type	Beschreibung Description	BK-Artikel-Nr.: BK-Article-No.:
1	-A1	1	Display	BOLL & KIRCH	BK2300	2 zeiliges universelles Display 2 lined universal Display	4300706
2	-A1	1	Patchkabel Patch cable	Reco	SFTP	Doppelt geschirmt, 0,5m, RJ 45 geschirmt, 0,5m, RJ 45 geschirmt, 0,5m, cat 6, gerade - gewinkelt Double shielded, 0.5m, RJ 45 shielded, 0.5m, RJ 45 shielded, 0.5m, cat 6, straight - angulated	4100308
3	-A2	1	E/A-Modul I/O-Modul	BOLL & KIRCH	BK2300	IN 20VAC, 6DI, 5 Relaisausgänge, 3 Ventilausgänge, Steuerung für BK2300 IN 20VAC, 6DI, 5 Relay outputs, 3 Valve outputs, Controller for BK2300	4300706
4	-A2-F1	1	Schmelzsicherung Safety fuse	ESKA	522.516	0,8A, 5x20mm, Träge 0,8A, 5x20mm, Passive	4200162
5	-A2-F2	1	Schmelzsicherung Safety fuse	ESKA	522.520	2A, 5x20mm, Träge 2A, 5x20mm, Passive	4200163
6	-F1	1	Sicherungsklemme Fused terminal	Conta-Clip	SIK 10/Z BG	10 mm², NS35, Beige, Schraubanschluss 10 mm², NS35, Fawn, Screw terminal	4200526
7	-F1	1	Schmelzsicherung Safety fuse	ESKA	632.717	1A, 6,3x32mm, Träge 1A, 6,3x32mm, Passive	4200146
8	-F2	1	Sicherungsklemme Fused terminal	Conta-Clip	SIK 10/Z BG	10 mm², NS35, Beige, Schraubanschluss 10 mm², NS35, Fawn, Screw terminal	4200526
9	-F2	1	Schmelzsicherung Safety fuse	ESKA	632.717	1A, 6,3x32mm, Träge 1A, 6,3x32mm, Passive	4200146
10	-F3	1	Sicherungsklemme Fused terminal	Conta-Clip	SIK 10/Z BG	10 mm², NS35, Beige, Schraubanschluss 10 mm², NS35, Fawn, Screw terminal	4200526
11	-F3	1	Schmelzsicherung Safety fuse	ESKA	632.717	1A, 6,3x32mm, Träge 1A, 6,3x32mm, Passive	4200146
12	-Q1	1	Haupt-/NOT-AUS-Schalter Main / Emergency stop switch	ABB	OT16F3	3 Polig, 16A, Bodenbefestigung 3 Pole, 16A, Bottom mounting	4200149
13	-Q1	1	Hilfskontakt Auxiliary contact	ABB	OA1G10	16A, 1NO, seitlich, für OT16...OT125 Hauptschalter 16A, 1NO, side mounting, for OT16...OT125 Main switch	4200617
14	-Q1	1	Hauptschaltergriff Main switch handle	ABB	OHYS2AJ	für Hauptschalter OT16...125F, Rot/Gelb, IP65, NEMA 1 for Main switch OT16...125F, Red/Yellow, IP65, NEMA 1	4200149
15	-Q1	1	Hauptschalterwelle Main switch shaft	ABB	OXS6X130	für Hauptschalter OT16...125F, 130mm, mit Türverriegelung for Main switch OT16...125F, 130mm, with Door lock	4200149
16	-Q2	1	Leistungsschutz Power contactor	ABB	BC6-30-10	4kW, 1NO, 24VDC, Schraubanschluss 4kW, 1NO, 24VDC, Screw terminal	4200148
17	-T1	1	Steuertransformator Control transformer	MDEXX	TAM3496-0EJ00-0FA2	einphasig, 65VA, IN 220-550VAC, OUT 20VAC 220VAC 24VDC, 50/60Hz, IP00, Schraubanschluss single-phase, 65VA, IN 220-550VAC, OUT 20VAC 220VAC 24VDC, 50/60Hz, IP00, Screw terminal	4200524
18	-X0	2	Schutzleiterklemme Protective conductor terminal	Phoenix Contact	UT 2,5-QUATTRO-PE	4mm², NS35, Grün/Gelb, Schraubanschluss 4mm², NS35, Green/Yellow, Screw terminal	4100073
19	-Z1	1	Kleingehäuse Small enclosures	Rittal	KX 1575 Y231292	300 x 300 x 155mm, RAL7035, IP65, Stahlblech, Ausführung B&K 23xx 300 x 300 x 155mm, RAL7035, IP65, sheet steel, version B&K 23xx	4300839
20	-Z1	1	Wandbefestigungshalter Wall mounting bracket	Rittal	KX 1590.010	10 mm, für AX und KX, Stahl 10 mm, for AX and KX, Steel	4300840

			Datum Date	16.05.2019		Hersteller Manufacturer	Materialliste Part list	BK-Artikel-Nr.: BK-Article-No.:	4302300	=	
			Bearbeiter Edited by	ogoeरिके		Boll & Kirch Filterbau GmbH	Filtertyp 6.61/6.61 Alarm DP Filter type 6.61/6.61 Alarm DP	Zeichnungs-Nr.: Drawing-No.:	4302300 Z46604	+	
REV01	Göricke	13.10.2021	Auftrag Order							Blatt Page	8
Revision Revision	Bearbeiter Edited by	Datum Date	Vorgang Process							von of	15

Materialliste

Part list

Nr. No.	BMK DT	Anzahl Quant.	Bezeichnung Designation	Hersteller Manufacturer	Typ Type	Beschreibung Description	BK-Artikel-Nr.: BK-Article-No.:
21	-Z1	3	Kabelverschraubung Cable gland	WISKA	EMSKV 20-25 EMV-Z	M20, Messing, vernickelt, EMV-fest, Kabeldurchmesser 9-17mm M20, Brass, nickel-plated, EMC-proof, Cable diameter 9-17mm	4100097
22	-Z1	3	Gegenmutter Locknut	WISKA	EMMU 20	M20, Messing, vernickelt M20, Brass, nickel-plated	4100309
23	-Z1	2	Kabelverschraubung Cable gland	WISKA	EMSKV 25-32 EMV-Z	M25, Messing, vernickelt, EMV-fest, Kabeldurchmesser 13-21mm M25, Brass, nickel-plated, EMC-proof, Cable diameter 13-21mm	4100098
24	-Z1	2	Gegenmutter Locknut	WISKA	EMMU 25	M25, Messing, vernickelt M25, Brass, nickel-plated	4100310
25	-Z1	3	Reduzierdichteinsatz Reduced seal insert	WISKA	RDE 25	Kabeldurchmesser 7-12mm, für M25 Kabelverschraubung Cable diameter 7-12mm, for M25 Cable gland	3250001
26	-Z1	2	Reduzierdichteinsatz Reduced seal insert	WISKA	RDE 32	Kabeldurchmesser 9-14mm, für M32 Kabelverschraubung Cable diameter 9-14mm, for M32 Cable gland	3250002
27	-Z1	1	Elastikpuffer Rubber bump	3M	Bumpon	selbstklebende, Grau self-adhesive, Gray	3500038
28	-Z1	2	Endwinkel End angle	Conta-Clip	ZES 35/2 BG	Beige, für NS35 Tragschiene Fawn, for NS35 Mounting rail	4100311

			Datum Date	16.05.2019		Hersteller Manufacturer	Materialliste Part list Filtertyp 6.61/6.61 Alarm DP Filter type 6.61/6.61 Alarm DP	BK-Artikel-Nr.: BK-Article-No.:	4302300	=	
			Bearbeiter Edited by	ogoeरिके		Boll & Kirch Filterbau GmbH		Zeichnungs-Nr.: Drawing-No.:	Z46604	Blatt Page von of	9 15
REV01	Göricke	13.10.2021	Auftrag Order								
Revision Revision	Bearbeiter Edited by	Datum Date	Vorgang Process								

Klemmenplan Terminal diagram

Funktionstext Function text	Kabelname Cable name	Kabeltyp Cable type	=+ #-F1 Vorsicherung Pre-protection						Kabelname Cable name	Kabeltyp Cable type	
			Ziel Destination		Klemme Terminal	Brücke Jumper	Quelle Source				Blatt Page Pfad Path
			Bezeichnung Designation	Anschluss Connection			Bezeichnung Designation	Anschluss Connection			
Einspeisung vom Netz Power supply input from mains			-Q1	L1			-T1	5	&1/ 3.1		

Klemmenplan Terminal diagram

Funktionstext Function text					Kabelname Cable name	=+#-F2 Vorsicherung Pre-protection					Kabelname Cable name						
					Kabeltyp Cable type	Ziel Destination		Klemme Terminal	Brücke Jumper	Quelle Source		Blatt Page Pfad Path	Kabeltyp Cable type				
						Bezeichnung Designation	Anschluss Connection			Bezeichnung Designation	Anschluss Connection						
Einspeisung vom Netz Power supply input from mains						-Q1	L2			-Q2	3	&1/ 3.1					

			Datum Date	16.05.2019		Hersteller Manufacturer	Klemmenplan Terminal diagram	BK-Artikel-Nr.: BK-Article-No.:	4302300	=
			Bearbeiter Edited by	ogoricke		Boll & Kirch Filterbau GmbH	Filtertyp 6.61/6.61 Alarm DP Filter type 6.61/6.61 Alarm DP	Zeichnungs-Nr.: Drawing-No.:	Z46604	+
REV01	Göricke	13.10.2021	Auftrag Order							Blatt Page
Revision Revision	Bearbeiter Edited by	Datum Date	Vorgang Process				von of	15		

Klemmenplan Terminal diagram

Funktionstext Function text	Kabelname Cable name	=+#-F3 Vorsicherung Pre-protection							Kabelname Cable name	
		Kabeltyp Cable type	Ziel Destination		Klemme Terminal	Brücke Jumper	Quelle Source			Blatt Page Pfad Path
			Bezeichnung Designation	Anschluss Connection			Bezeichnung Designation	Anschluss Connection		
Einspeisung vom Netz Power supply input from mains			-Q1	L3			-T1	1	&1/ 3.1	

			Datum Date	16.05.2019		Hersteller Manufacturer	Klemmenplan Terminal diagram	BK-Artikel-Nr.: BK-Article-No.:	4302300	=
			Bearbeiter Edited by	ogoricke		Boll & Kirch Filterbau GmbH	Filtertyp 6.61/6.61 Alarm DP Filter type 6.61/6.61 Alarm DP			+
REV01	Göricke	13.10.2021	Auftrag Order							Blatt Page
Revision Revision	Bearbeiter Edited by	Datum Date	Vorgang Process				Zeichnungs-Nr.: Drawing-No.:	Z46604	von of	15

Klemmenplan Terminal diagram

Funktionstext Function text			-W2	-W1	Kabelname Cable name	= + # -X0 Einspeisung Feeder					Kabelname Cable name			
			Kabeltyp Cable type	Ziel Destination		Klemme Terminal	Brücke Jumper	Quelle Source		Blatt Page Pfad Path	Kabeltyp Cable type			
				Bezeichnung Designation	Anschluss Connection			Bezeichnung Designation	Anschluss Connection					
Einspeisung vom Netz Power supply input from mains				GNYE		PE	·	-U2	PE1	&1/ 3.1				
Getriebemotor Gear motor			GNYE			PE	·	-T1	PE	&1/ 5.4				

Klemmenplan Terminal diagram

Funktionstext Function text	Kabelname Cable name	Kabeltyp Cable type	= + # - X2 Filter Filter							Kabelname Cable name	-W2
			Ziel Destination		Klemme Terminal	Brücke Jumper	Quelle Source		Blatt Page Pfad Path		
			Bezeichnung Designation	Anschluss Connection			Bezeichnung Designation	Anschluss Connection			
Getriebemotor Gear motor			-M1	U1	U	.	-Q2	2	&1/ 5.4		
Getriebemotor Gear motor			-M1	V1	V	.	-Q2	4	&1/ 5.4		
Getriebemotor Gear motor			-M1	W1	W	.	-Q2	6	&1/ 5.4		
Getriebemotor Gear motor			-M1	PE	PE	.	-X0		&1/ 5.4	GNYE	
Differenzdruck DP 75% Differential pressure DP 75%			-A2	40	1			1	&1/ 4.7		
Differenzdruck DP 75% Differential pressure DP 75%			-A2	39	2			2	&1/ 4.7		
Differenzdruck zu Hoch DP 100% Differential pressure too High DP 100%			-A2	38	3			1a	&1/ 4.6		
Differenzdruck zu Hoch DP 100% Differential pressure too High DP 100%			-A2	37	4			3a	&1/ 4.6		
Endschalter S2Q Limit switch S2Q			-A2	32	5			21	&1/ 4.3		
Endschalter S2Q Limit switch S2Q			-A2	31	6			22	&1/ 4.3		
Spülventil Flushing valve			-Y1	x1	7		-A2	8	&1/ 4.1		
Spülventil Flushing valve			-Y1	x2	8		-A2	9	&1/ 4.2		
					PE	.			&1/ 4.4		

			Datum Date	16.05.2019		Hersteller Manufacturer	Klemmenplan Terminal diagram	BK-Artikel-Nr.: BK-Article-No.:	4302300	=
			Bearbeiter Edited by	ogoeरिके		Boll & Kirch Filterbau GmbH	Filtertyp 6.61/6.61 Alarm DP Filter type 6.61/6.61 Alarm DP	Zeichnungs-Nr.: Drawing-No.:	Z46604	+
REV01	Göricke	13.10.2021	Auftrag Order							Blatt Page
Revision Revision	Bearbeiter Edited by	Datum Date	Vorgang Process						von of	15

Klemmenplan Terminal diagram

Funktionstext Function text	Kabelname Cable name	= + # - X2 Filter Filter							Kabelname Cable name	
		Kabeltyp Cable type	Ziel Destination		Klemme Terminal	Brücke Jumper	Quelle Source			Blatt Page Pfad Path
			Bezeichnung Designation	Anschluss Connection			Bezeichnung Designation	Anschluss Connection		
					PE	.		&1/ 4.6		
					PE	.		&1/ 4.6		